



- **Portable USB Device**
- **Up to 2 Dual Redundant MIL-STD-1553 Channels**
- **16 User programmable DIO's**
- **USB Powered or Externally Powered**
- **Graphical User Interface Software for Bus Analysis and Simulation**
- **MIL-STD-1553 Programmable as Bus Controller or Remote Terminal or Monitor Terminal**
- **Direct Coupled or Transformer Coupled**
- **Software Driver Support for Windows 2000/XP.**

## DESCRIPTION

The USB-1553 module is a small, portable, USB device that provides new levels of performance and flexibility for systems interfacing to a MIL-STD-1553 data bus. There are up to two dual redundant MIL-STD-1553 channels operating in BC, RT, MT, and RT/MT modes. The unit can be powered directly from the USB interface or by an external power source (optional). The device includes the MIL-STD-1553 C API (Application Programming Interface) library and drivers, along with source code samples, and detailed documentation.

## APPLICATION

This module is the perfect COTS solution for MIL-STD-1553 data bus systems. Its small size, lightweight, and durable construction makes it an ideal choice for use in avionics labs, field service, flight line test equipment, and flight instrumentation applications. The USB interface makes it suitable for use with desktop, laptop, or tablet computers.

## DISCRETE I/O

The device includes 16 (digital 5V) discrete that are individually programmable as inputs or outputs (Open/Ground Discrete). The discrete outputs can be used for a variety of purposes, including triggering events, indicating status, and general-purpose use.

## POWER

The module has been designed to source power from either one or two USB ports. In cases where the primary USB port cannot supply the necessary power, a second USB port may be used for power only. In cases where two USB ports are insufficient, a low-cost 5V AC adaptor may be used to power the device. The unit requires that a minimum of 500 mA of current is available per USB port from the moment the USB connection is made. When the unit is running exclusively from USB power (1 or 2 ports), a connection to a high-powered USB hub port is required. The high-powered USB hub port must have an input voltage range of 4.75V to 5.25V.

The unit contains a DC power jack for connection to an external 6V power source. Once connected, the USB device will stop drawing power from the USB port(s). The allowable range for this DC input is  $5V \pm 5\%$  (4.75V to 5.25V). The DC jack is designed to interface with off-the-shelf AC adaptors.

## SOFTWARE

This USB Avionics Device includes a Bus Monitor and Analysis Software. Source code provided for samples, and detailed documentation. The device comes with a powerful set of library functions to access the entire MIL-STD-1553B functionality. The drivers are designed in a modular fashion consisting of component functions and application functions. The user's test program can be developed with few calls to the driver by using the set of application functions provided. Driver and high-level API libraries for DOS, Windows 2000/XP are available. Sample programs for BC, RT, MT modes are included.

## MIL-STD-1553 CHANNELS

Each 1553 channel can emulate as a Bus Controller (BC), a Remote Terminal (RT), or a Bus Monitor (MT). Standard features include 64KB of RAM per 1553 channel, transformer and direct coupling, triggers, extensive BC & RT frame structures, RT Status Bit and Mode Code responses, along with advanced BC functionality. The advanced BC architecture provides a high degree of flexibility and autonomy by providing message schedule control, minimizing host overhead for asynchronous message insertion, facilitating bulk data transfers, double buffering, message retry, bus switching strategies, data logging, and fault reporting.

# ATS-USB-1553

MIL-STD-1553B USB DEVICE

The RT architecture provides flexibility in meeting all common MIL-STD-1553B protocols. The choices of RT buffering and interrupt options provide robust support for synchronous and asynchronous messaging, while ensuring data sample consistency and supporting bulk data transfers.

The interface includes a message monitor mode and a combined RT/MT mode where the MT will monitor all 1553 communications on the bus including the 1553 Channel's assigned RT addresses.

The Bus Monitor Mode provides for Selective Message Monitoring and Combined RT/Message Monitor Mode. Besides providing monitor filtering based on RT address, T/R bit, and sub address, the message monitor eliminates the need to determine the start and end of messages by software. A combined RT/MT mode allows the device to run in both modes of operation at the same time on the bus.

## PRODUCT SPECIFICATIONS

### MIL-STD-1553B Interface

- Up to Two Dual Redundant MIL-STD-1553 Channels
- Transformer and Direct Coupled 1553 I/O
- 64KB RAM per 1553 Channel
- High Level 1553 C API Software Library Interface
- BC, RT, MT, RT/MT Operating Modes

### 1553 Bus Controller

- Minor and Major Frame Scheduling to Control Timing of 1553 Messages
- High and Low Priority Asynchronous Message Insertion
- Modify Messages or Data while BC is running
- Conditional Messages or Subroutines based on User Defined Conditions
- Multiple BC retry programmable options
- Automatic retries on alternate Bus
- Inter Message Gap from 8us to 65ms
- Frame Auto Repeat up to 5s
- Programmable response timeout up to 130us

### 1553 Remote Terminal

- Choice of Sub-address Single Message, Double Buffering, Circular Buffering or Global Circular Buffering
- Stack with Descriptors for Individual Messages
- Message Status, Time Tag, Command Word, Data Words
- Programmable Command Illegalization
- Programmable Busy by Sub-address
- Software-Programmable RT Address
- Busy Bit programmable by Sub address
- Alpha numeric Message ID

### 1553 Monitor Terminal

- Selective Message Monitor and Word Monitor
  - Filter Based on RT Address, T/R bit, Sub-address Message Status, Time Tag, Command Word, Data Words
  - Simultaneous RT/Message Monitor Option
  - Dynamic Data Updation
  - Bus Error Status
  - Bus Load
  - Unique Message Identifier
  - Message periodicity
  - Record and Replay Option
- Software Support
- Driver and high-level API libraries for Windows 2000/XP.
  - Sample Applications will be provided to help users quickly setup and use the card.

### Physical

- Durable Enclosure with covers for 1553 connectors Environmental

### Commercial

- Operating temperature: 0° C to +50° C
- Storage temperature: -20° C to +70° C

### Industrial

- Operating temperature: -20° C to +55° C
- Storage temperature: -30° C to +65° C

### Power

- +5V USB powered or +5V External Powered through Adapter.

### Warranty

- 1 year limited warranty

## ORDERING INFORMATION

### Hardware Selection

#### ATS-USB-1553 - Controller - Channels - DIO - Ruggedization

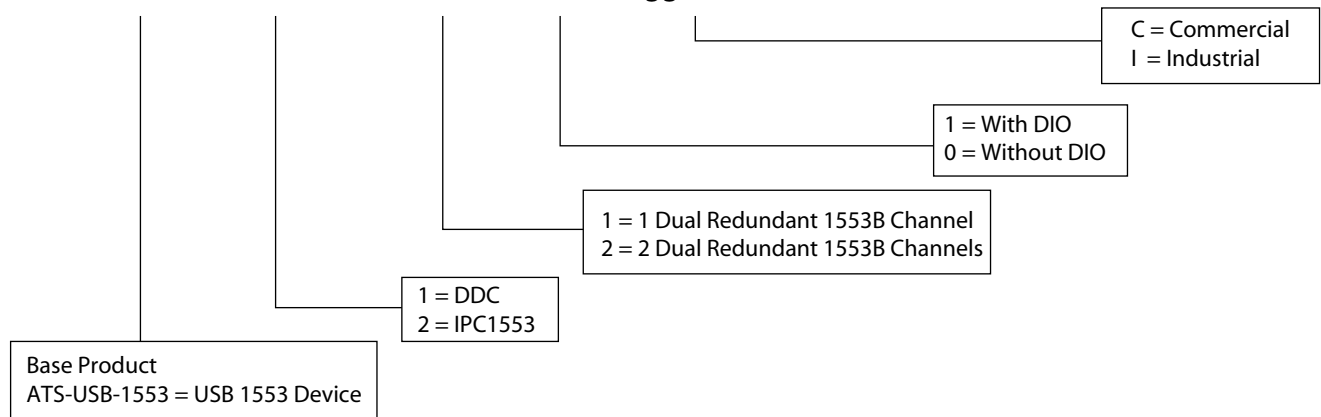

Anuva Technologies Pte Ltd  
No.6, Eu Tong Sen Street, The Central, #07-16, Singapore 059817

P +65 6221 8260 F +65 6221 7820

[www.anuvatechnologies.com](http://www.anuvatechnologies.com)

### Distributor/Reseller